

# TremLock® RF Panel

## Flush Metal Panel

### FEATURES

- Versatile
- Tongue-and-Groove

### BENEFITS

- Can be used in vertical or horizontal applications
- No Exposed Fasteners



### DESCRIPTION

TremLock RF Panels is a tongue-and-groove interlock panel used on vertical applications on fascias. The TremLock RP Panel can be used as a soffit panel.

### BASIC USES

Tongue-and-groove interlock panel used on vertical applications on fascias. Can be used as a soffit.

### SYSTEM DESIGN

The TremLock RF Panel is a 1 1/2" deep flush metal panels designed for use in vertical and horizontal applications. Available 12" panel width options include: vee grooves, inverted plank, reveals of up to 3", or a traditional smooth appearance. Regardless of the pattern, the 1 1/2" depth and the tongue-and-groove engagement remain the same. 2'0" min / 8'0" max length for 24 ga. 2'0" min / 15'0" max length for 22 ga.

### FINISH/COLOR

Acrylic Coated Galvalume®  
Fluoropolymer (Kynar 500® PVDF resin-based)  
Oil canning is inherent in all metal panels and is not cause for panel rejection.

### APPLICATION

Refer to Installation Manual for application data.

### SECTION PROPERTIES & PROFILES

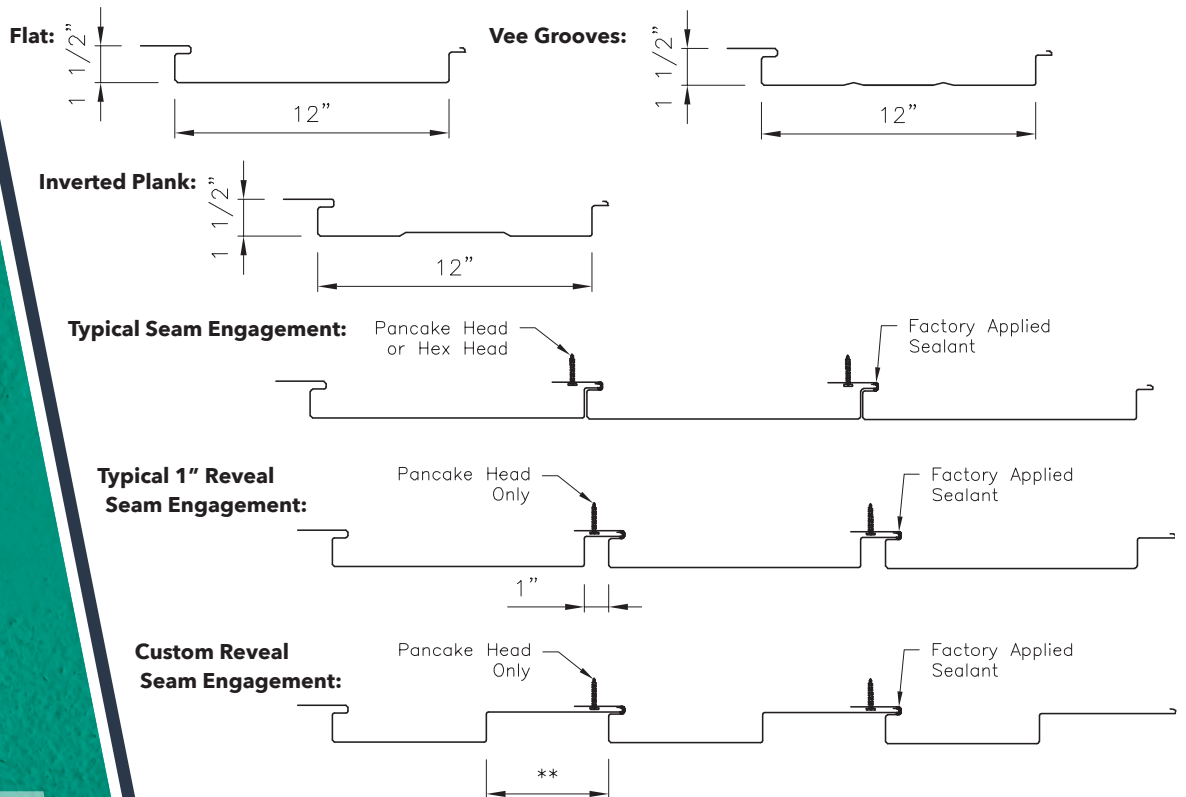

# TremLock® RF

## CODES/APPROVALS

## MAINTENANCE

## PRECAUTIONS

## TECHNICAL SUPPORT

TITLE OF TEST	TEST METHOD
Uplift Testing	ASTM E1592

Your local Tremco Roofing Sales Representative can provide you with effective maintenance procedures which may vary, depending upon specific conditions. Periodic inspections, early repairs and preventative maintenance are all part of a sound roof program.

Users must read container labels and Safety Data Sheets for health and safety precautions prior to use.

Your local Tremco Roofing Sales Representative, working with the Technical Service Staff, can help analyze conditions and needs to develop recommendations for special applications.



Roofing & Building Maintenance

[www.tremcoroofing.com](http://www.tremcoroofing.com)  
3735 Green Road  
Beachwood, Ohio 44122  
1.800.852.6013

50 Beth Neelson Drive  
Toronto, Ontario M4H 1M6  
1.800.668.9879

Tremco is a US Registered trademark of Tremco Incorporated.

The information provided on this data page supersedes all previous data concerning this product and its application.

The Statements provided concerning the materials shown are intended solely as a general guide for material usage and are believed to be true and accurate. Since the manner of use is beyond our control, Tremco DOES NOT MAKE NOR DOES IT AUTHORIZE ANY WARRANTY OF MERCHANTABILITY OR FITNESS FOR ANY PURPOSE, OR ANY OTHER WARRANTY, GUARANTEE OR REPRESENTATION, EXPRESSED OR IMPLIED, CONCERNING THIS MATERIAL EXCEPT THAT IT CONFORMS TO TREMCO'S PRODUCT SAMPLE. Buyer and user accept the product under those conditions and assume the risk of any failure, injury of person or property and loss or liability resulting from the handling, storage or use of the product, whether or not it is handled, stored, used in accordance with directions or specifications. UNDER NO CIRCUMSTANCE SHALL TREMCO BE LIABLE FOR CONSEQUENTIAL OR INCIDENTAL DAMAGES ARISING FROM ANY BREACH OF WARRANTY. IN ALL CASES, TREMCO'S LIABILITY IS LIMITED, AT TREMCO'S OPTION, TO THE REPLACEMENT OF GOODS, OR THEIR VALUE, PROVEN TO BE DEFECTIVE IN MANUFACTURING.

TremLock® is a U.S. registered trademark of Tremco Incorporated.

Kynar 500® is a U.S. registered trademark of Arkema Inc.

Hylar 5000® is a U.S. registered trademark of Solvay Solexis, Inc.

Galvalume® is a U.S. registered trademark of BIEC International Inc.

Fluoropon® is a U.S. registered trademark of SWIMC LLC.